

NOBILI



MEC

Elevatori a forche portati

Tractor mounted fork-lifts

Tractoelevadores suspendidos



Gli elevatori a forche portati della serie MEC sono attrezzature portate applicabili ai tre punti del sollevatore posteriore del trattore. La particolare progettazione e realizzazione degli organi di sollevamento consentono all'operatore la massima visibilità durante il lavoro. Può funzionare tramite l'olio del circuito idraulico della trattoria oppure a richiesta tramite una pompa autonoma azionata dalla presa di forza. Per soddisfare le varie esigenze di lavoro può essere equipaggiato con cappello stringicasse, comandi elettrici, forche per rotoballe, rovesciatore laterale da 500 kg, rovesciatore laterale con bloccaggio bins idraulico e contenitore uva.

MEC tractor mounted fork-lifts can be fitted to the rear three-point linkage of the tractor. Its special lifting design and manufacturing enables the operator the maximum view while working. The unit can be operated by the hydraulic system of the tractor or, upon request, by a separate and independent hydraulic drive group, operating thanks to the tractor PTO. In order to satisfy different working needs, it is possible to equip the fork-lift with case holder, electric controls, forks for round bales, bin tipper (500 kg capacity), bin tipper with bin hydraulic blocking and grape container.

Los tractoelevadores suspendidos de la serie MEC se aplican a los tres puntos del levantador posterior del tractor. El diseño especial y la realización de los trozos de levantamiento permiten al operador la máxima visibilidad durante el trabajo. Puede funcionar por el aceite del circuito hidráulico del tractor o bien, a petición, por una bomba autónoma accionada para la toma de fuerza. Para satisfacer las varias exigencias de trabajo, es posible montar la tapa por el bloqueo de la carga, los mandos eléctricos, horchas para pacas redondas, volquete lateral de 500 kg, volquete lateral con bloqueo bins hidráulico y el contenedor por las uvas.

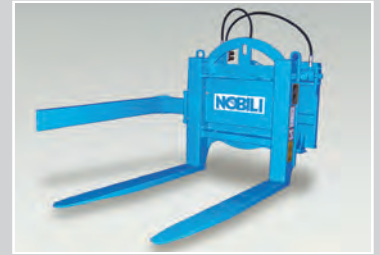
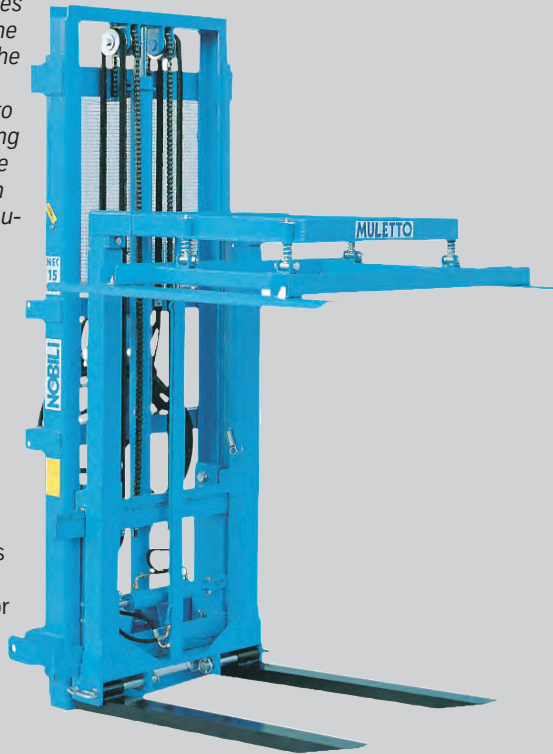

Rovesciatore laterale
Bin tipper
Volquete lateral



Comando elettrico con selettore joystick
Electric control unit with joystick
Mando eléctrico con selector joystick



Comando elettrico con distributore ON/OFF
Electric control unit with ON/OFF distributor
Mando eléctrico con distribuidor ON/OFF

MOVIMENTI MOVEMENTS MOVIMIENTOS

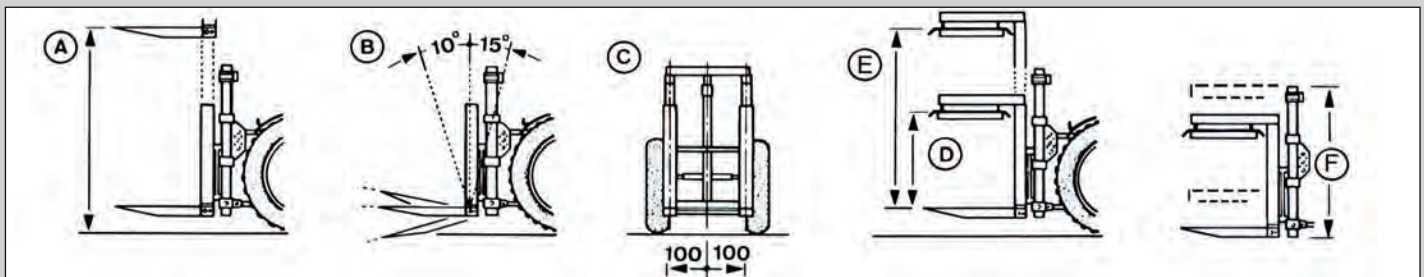

CARATTERISTICHE TECNICHE TECHNICAL SPECIFICATIONS CARACTERÍSTICAS TÉCNICAS		Mec 15-220	Mec 15-270	Mec 15-320	Mec 15-400
Portata / Lifting capacity / Capacidad de elevación	kg	1500	1500	1500	1500-1350
Elevazione / Lifting / Elevación	(A) mm	2200	2700	3200	4000
Brandeggio / Tilt / Inclinación	(B) mm	-10°/+15°	-10°/+15°	-10°/+15°	-10°/+15°
Traslazione laterale / Side-shift / Traslación lateral	(C)	200	200	200	200
Stringicasse Top load cover Tapa por el bloqueo de la carga	(D) min mm	1350	1350	1350	1350
	(E) max mm	2450	2450	2450	2450
Larghezza forche / Forks width / Ancho horcas	mm	550-750	550-750	550-750	550-750
Ingombro max / Overall dimensions / Tamaño máximo	(F) mm	1750	2000	2250	2650
Peso / Weight / Peso	kg	465	486	508	541

Concessionario / Dealer:

